

# M30



## Large Integrated Scrubber-Sweeper

- Superior results in just one pass – with FloorSmart® integrated cleaning system
- Lower Total Cost of Ownership™ without compromising safety or performance
- Reliably clean up to three times longer than conventional scrubbing with FaST®



*The Safe Scrubbing Alternative®*

# Eliminating the complexity of traditional sweeper-scrubbers.

A fully-integrated scrubber-sweeper, the M30 is engineered for dependable, industrial-strength cleaning when scrubbing, sweeping or doing both at once.

## Maximize your productivity

Built with a rugged steel frame, long-lasting Duramer™ construction, and ISO 9001 certified quality manufacturing, the M30 is a machine you can depend on every day of the week.

## Dramatically Lower Total Cost of Ownership

Without compromising safety or performance, we've reduced the total cost of ownership for machines that both scrub and sweep. With two brushes instead of four, EasyOpen™ service access, and 14% fewer parts, the M30 is one of the most efficient, industrial cleaning machines available.

## Safer for your operators, customers, and employees

Protect your operator, your customers, and your facility with Tennant's exclusive ErgoSpace™ operator compartment, FaST® scrubbing technology, Hygenic® cleanable tanks and Grip-N-Go™ corner rollers.



## Reliably provide a clean, safe, and productive environment with FaST



Reduce the risk of slip-and-fall with National Floor Safety Institute (NFSI) certified FaST foam activated scrubbing

technology by increasing floor traction up to 21%.

Ideal for smoother, less porous surfaces, FaST allows up to 110 minutes of cleaning per tank – three times longer than conventional scrubbing. Gain 25 hours of productivity with one 4-liter FaST-PAK®, while reducing the potential for slip and fall accidents.



## PRODUCTIVE. CLEAN. SAFE.



Reduce downtime, service time, and maintenance costs by quickly accessing the heart of the M30 with EasyOpen service access.



Achieve outstanding results in the harshest environments with dual cylindrical brushes combined with a large 95 gal / 360 L recovery tank and 7 ft<sup>3</sup> / 198 L hopper that allows you to sweep and/or scrub in a single pass.



Maintain safety and improve efficiency for operators and your facility with the outstanding visibility and ergonomics designed into the ErgoSpace operator compartment.

## INSIDE THE M30



**A**

Superior maneuverability for cleaning in tight areas with front wheel steering and high traction scrubber tires.

**B**

Reduce training time with Touch-N-Go™ one-button operation.

## KEY AVAILABLE FEATURES

### Increase productivity up to 3 hours

**ES**® Dramatically extend cleaning time, even when cleaning porous concrete, by continually filtering and recycling recovered solution with the ES® system.



### Widen cleaning path from 48 up to 64 inches / 1,220 to 1,625 mm

Achieve superior edge-cleaning capabilities and maximum productivity with the side brush.



### Enhance cleaning flexibility

Blast clean hard-to-reach areas easily with the 25 ft / 7.6 m, 2200 psi pressure washer.



### Protect operator and machine

Ensure safety in severe environments with heated and cooled soft cab.

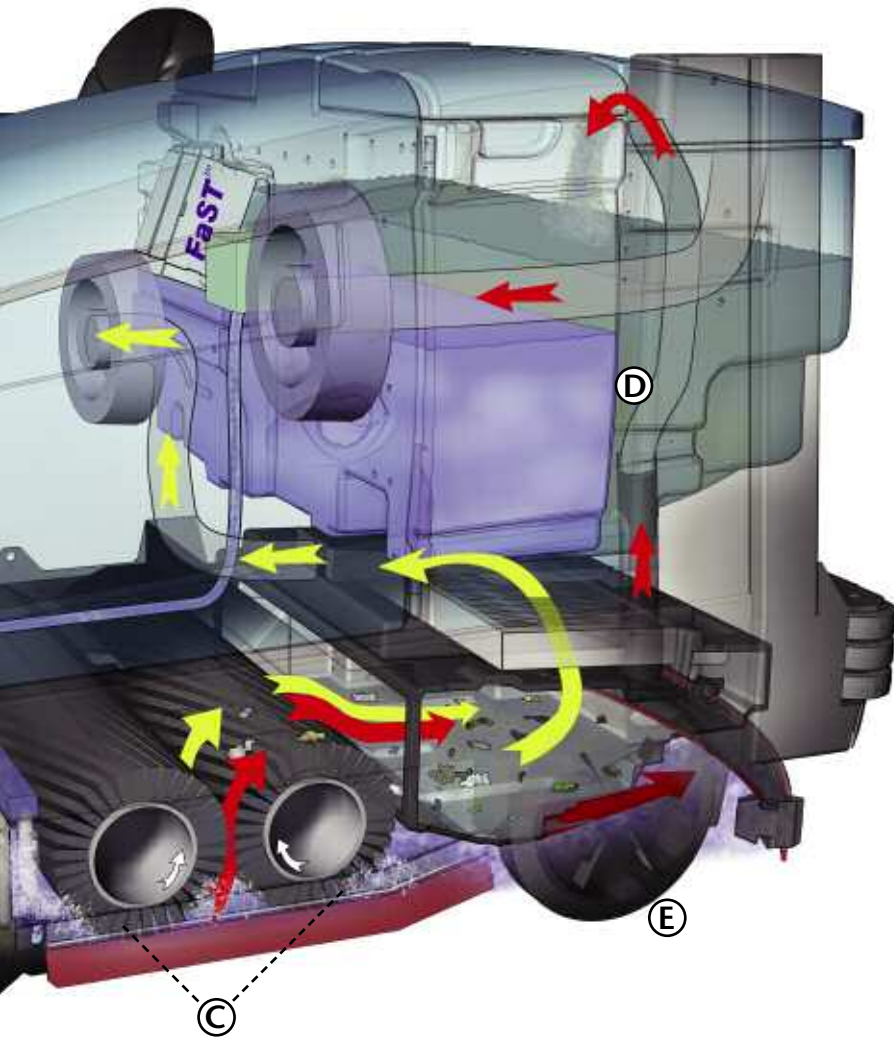

C

**C**  
Integrated scrubbing and sweeping system eliminates machine complexity and improves reliability.



D

**D**  
Maximize productivity and safety with easy-to-clean-and-sanitize large Hygenic® solution and recovery tanks.

E

**E**  
Maneuver easily, indoors and out, with rugged 18 in / 460 mm tires.

# M30 INTEGRATED SWEEPER-SCRUBBERS

	RESULT	FEATURE	
Increased Safety	Reduces potential slip-and-fall accidents with NFSI certified detergents	FaST® scrubbing technology	
	Improves visibility and response time to obstacles	ErgoSpace™ operator compartment	
	Reduces the risk of accidental hopper fires	Thermo-Sentry™ hopper sensor	
	Protects your facility and machine against damage	Grip-N-Go™ corner rollers	
	Independent laboratory certified for global safety compliance	Underwriter's Laboratory (UL®) Certified	
Reduced Costs	Less complexity, fewer parts to repair, and only 2 brushes to replace	FloorSmart® integrated machine	
	Quick, easy maintenance allowing maximum uptime	EasyOpen™ service access and on-board diagnostics	
	Reduces maintenance and replacement parts due to squeegee damage	SmartRelease™ break-away squeegee	
	Reduces component wear while delivering consistent hydraulic power for better cleaning	MaxPro™ hydraulic technology	
Maximum Productivity	Avoid detergent overuse and conserve water	ES® Extended Scrub system with detergent metering	
	Provide easy visibility to solution and recovery tanks for cleaning and sanitization	Hygenic® tanks	
	Control the flow of the water leaving the tanks without the normal fuss and mess	Variable Drain Valves™	
	Intuitive control panel that remembers last settings allows for operation with just a touch of a button	Touch-N-Go™ control panel	





## GENUINE TENNANT PARTS, SUPPLIES & SERVICE

### Genuine Tennant Parts Advantage

Operate your machine with confidence by choosing genuine Tennant parts. Only authentic Tennant parts are engineered in conjunction with Tennant equipment. For years of worry-free operation, accept only genuine parts and supplies.

### Foam-based FaST:

#### Your Key to Peak Productivity and Safety

Using innovative foam-based detergent, machines with FaST increase productivity, eliminate the need for operators to handle chemicals, and leave just-cleaned floors immediately dry and safe for traffic.

### Industry's Only Factory-Direct Service Network

Providing world-class response, completion times and on-site machine service, our factory-trained network of 450 service techs are dedicated to keeping your cleaning program up and running.

*Choose financing options through Tennant for simple, quick financing with flexible upgrade options, and no long-term obligation. Financing is offered through Tennant Financial® Services and Tennant Capital® Services.*

## WARRANTY

All parts (excluding batteries) have a 36 month warranty under normal use and service, on-site service labor coverage of warranty items for 24 months, and 6 months travel.

## M30 RIDER SCRUBBER-SWEEPER

### Integrated Cleaning System

Cleaning path	48 in	1,220 mm
With scrubbing side brush	62 in	1,575 mm
With sweeping side brush	64 in	1,625 mm

### Cylindrical main brushes

Brush speed	480 rpm	480 rpm
Brush down pressure (up to)	390 lb	177 kg
Brush diameter (2)	12 in	305 mm

### Side brush

Brush speed	150 rpm	150 rpm
Scrubbing brush diameter	16 in	410 mm
Sweeping brush diameter	21 in	535 mm

### Tanks

Solution tank	75 gal	284 L
Solution capacity with ES®	100 gal	379 L
Recovery tank	95 gal	360 L
Demisting chamber	20 gal	76 L

### Debris hopper

Volume capacity	7 ft <sup>3</sup>	198 L
Weight capacity	650 lb	295 kg
Dump height (variable to)	60 in	1,525 mm

### Vacuum fans

Scrubbing fan speed	11,000 rpm	11,000 rpm
Scrubbing fan water lift	35 in	890 mm
Sweeping fan speed	6,500 rpm	6,500 rpm
Sweeping fan airflow	290 cfm	8.2 m <sup>3</sup> /min

### Dust Control System

Filter system	Synthetic fiber panel	Synthetic fiber panel
Filter area	78 ft <sup>2</sup>	7.3 m <sup>2</sup>
Dust filtration (to)	3 microns @ 99% efficiency	3 microns @ 99% efficiency
Shaker mechanism (automatic)	Timed, beater bar	Timed, beater bar

### Propelling System

Propel speed forward (variable to)	8 mph	13 km/h
Propel speed reverse (variable to)	3 mph	4.8 km/h
Engine-gasoline/LPG (1.6 L)	55 hp	34 kW
Engine-diesel turbo (1.5 L)	40.5 hp	30 kW
Gradeability		
Transport at gross weight	8.0 deg/14%	8.0 deg/14%
Working (cleaning)	6.0 deg/10%	6.0 deg/10%
Ground clearance (transport)	3 in	80 mm

### Machine Dimensions

Length	108 in	2,745 mm
Width		
Frame	58 in	1,475 mm
Rear squeegee	59 in	1,500 mm
With side brush	64 in	1,625 mm
Height	58 in	1,475 mm
With overhead guard	84 in	2,135 mm
Weight (empty)	4,000 lb	1,815 kg
Minimum aisle turn	125 in	3,175 mm

## SEEING IS BELIEVING

See for yourself how the M30 scrubber-sweeper delivers clean, safe floors. For a demonstration or additional information, call 800.553.8033.

### Tennant

P.O. Box 1452  
 Minneapolis, MN 55440-1452  
 800.553.8033 | 763.540.1200  
 In Quebec: 514.335.6061

[www.tennantco.com](http://www.tennantco.com)  
[info@tennantco.com](mailto:info@tennantco.com)